

ALL DIMENSIONS IN mm  
 UNLESS STATED,  
 DO NOT SCALE.  
 IF IN DOUBT ASK.  
 THIRD ANGLE PROJECTION

CUSTOMER: -	START DATE: 06.01.94	PROJECT: -
DRAWN BY: DGT	UNLESS STATED	PRODUCT: TRUSS / TOWER ACCESSORIES
POSITION TOLERANCE: -	SCALE: NTS	DRAWING TITLE: FIXED CASTOR ASSEMBLY DRAWING
ANGULAR TOLERANCE: -	UNLESS STATED	
SQUARENESS TOLERANCE: -	UNLESS STATED	

PART No. G0901	SHEET No. 01	OF 01	ISSUE 1
DRAWING No. G0901-S	DRAWING TYPE 1/1		

This drawing/document is COPYRIGHT and the property of JAMES THOMAS ENGINEERING. It must not be copied (in whole or in part) used for manufacture or otherwise disclosed without the consent of the company. Copies of this drawing/document made by any method must include a copy of this legend.

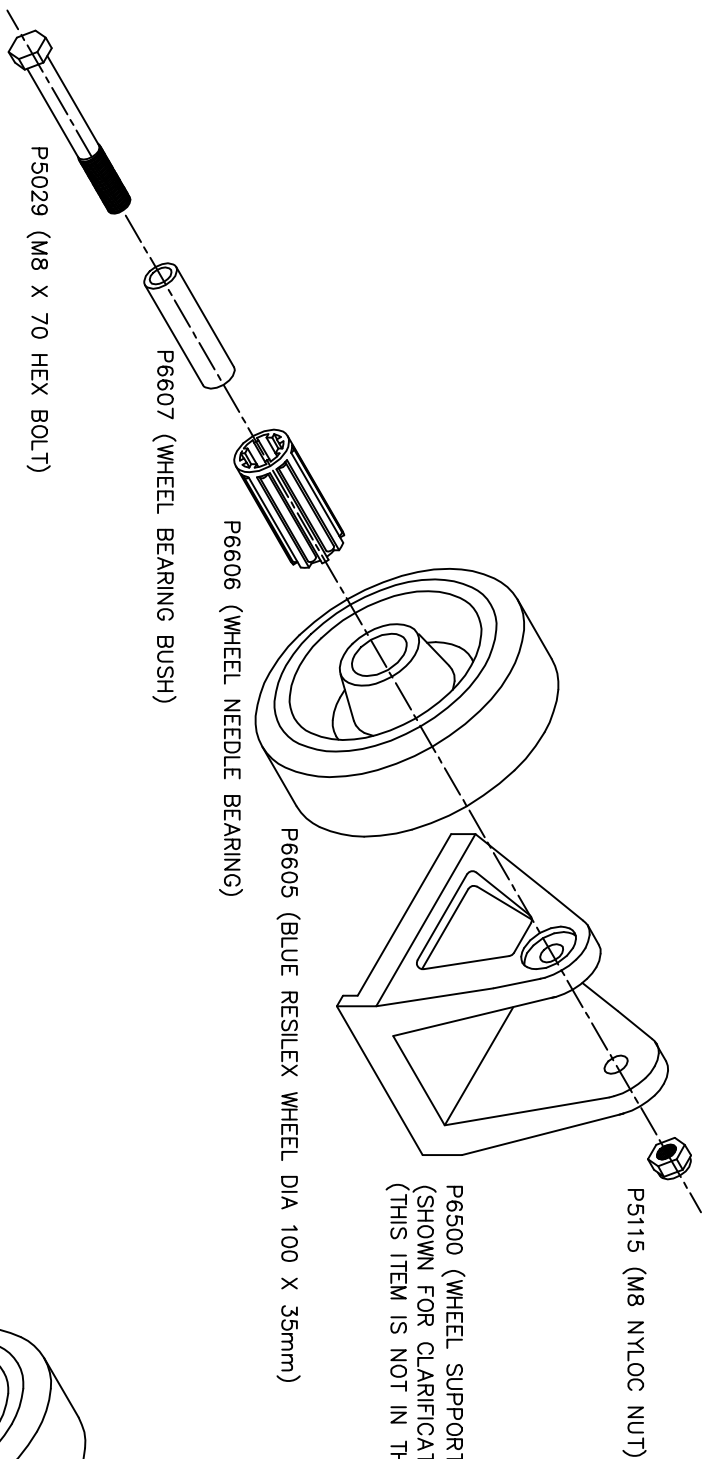

EXPLODED ISOMETRIC VIEW

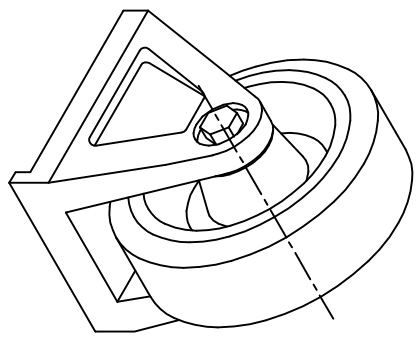

ASSEMBLED ISOMETRIC VIEW