

PAR 36 HANGING AND RELAMPING INSTRUCTIONS

The Thomas PAR lanterns are to be hung with either a single hook clamp with bolt set (part number D0003), a variable hook clamp (D0101 with G0061 bolt set), an extruded pipe clamp (G0395); or mounted to an appropriate surface that is mechanically sound. Caution- injury to persons and damage to the lamp and/or mounting surface may result if the fixture is pulled from the surface. To reduce the likelihood of such injury or damage, mount only to a surface that is mechanically sound. To install a hanging device as listed above on the PAR 36 without transformer housing, (install bolt through hole provided in yoke using washers either side of yoke and tighten nut (or bolt) to the proper torque.) On the PAR 36 with transformer housing use the bolt provided on the unit install washers and nut and tighten to the proper torque.

To replace the lamps on PAR 36 ashtray units (figure 1) disconnect the unit from the electrical supply and allow the unit to cool. Remove both back cap screws and star washers. Remove the back cap in a back and upward motion (use caution as the back cap is the only thing holding the lamp in place). Remove the screws from the lamp and pull back the ring terminals and wire. Remove the lamp from fixture. Reverse the steps above to install the new lamp.

To replace the lamps on other PAR 36 units (figure 2) disconnect the unit from the electrical supply and allow the unit to cool. Pull up on the spring and plunger (the spring and plunger does not remove). Remove the back cap in a back and downward motion (notice the alignment pin in the back cap and hole in the fixture body). Remove the screws from the lamp and pull back the ring terminals and wire. Remove the lamp from fixture. Reverse the steps above to install the new lamp.

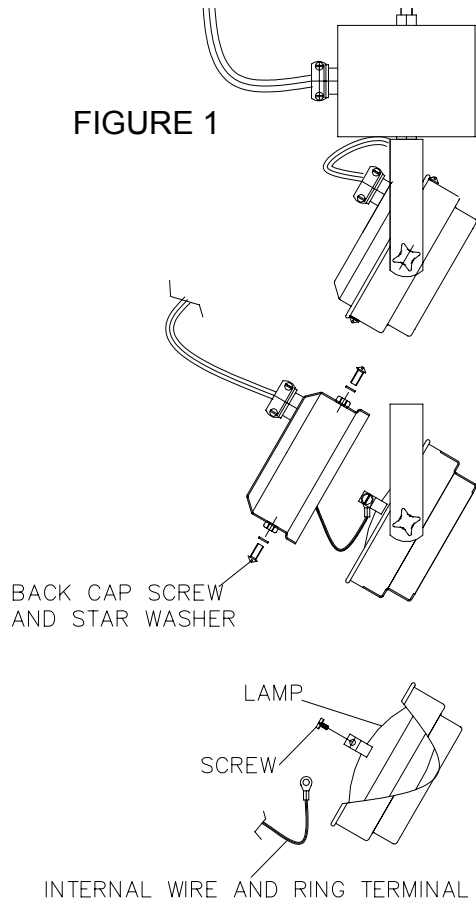

FIGURE 1

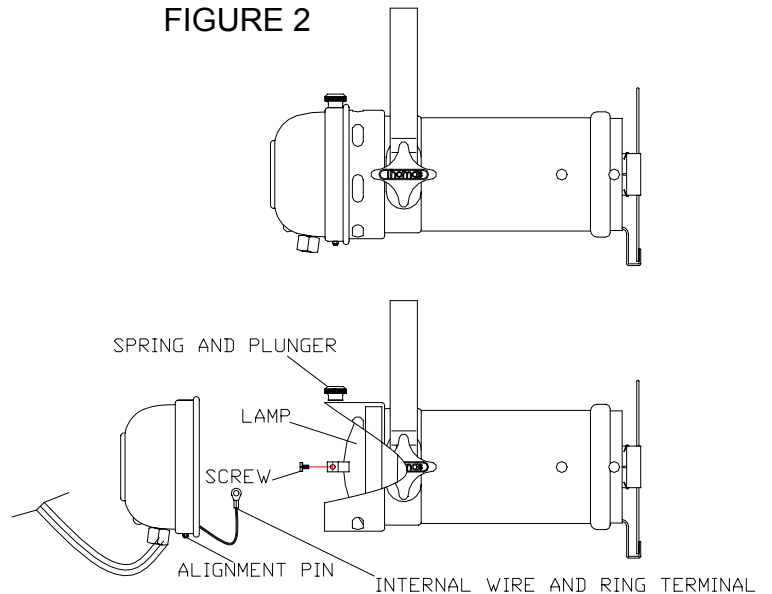

FIGURE 2

Please retain this instruction leaflet for future reference